



Product of Brother's Equipment Inc.



Made In The U.S.A

Setting the Lugging Industry Standard Since 1962

LUGGER

Container Handling System



Load



Transport



Dump

4 Generations of Dedicated Service

P 800-578-8471

W www.TheACEAdvantage.com

120-RC-50/60 Luger Hoist 50,000/60,000 lbs. Lifting Capacity

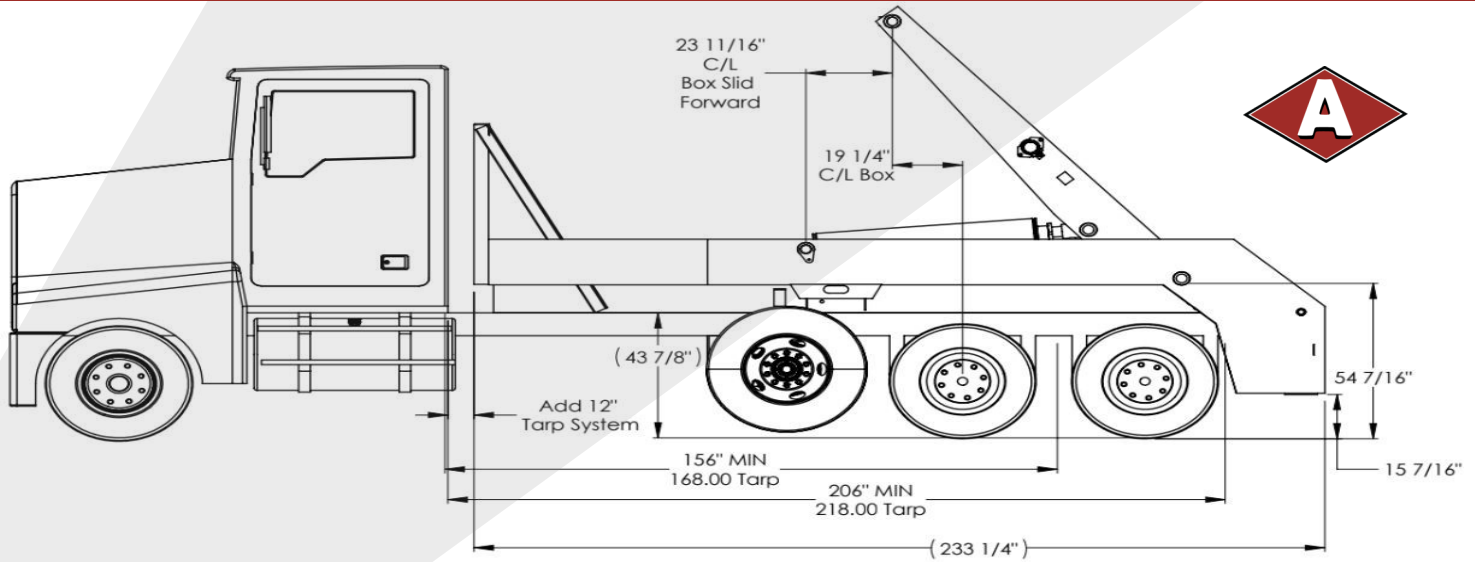

- Dump Keys Provide the Safest Dump Operation!
- Complies with Cargo Securement Requirements on Containers 48" or Taller! Title 49: § 393.102 without additional tiedowns!



- Non-Oscillating Outriggers
- Easy-to-Use Access Panel
- Decreased Chance of Damage



- Arm Hinge: Above Bed
- Prevents damage to containers and rear of unit.
- Higher Degree Dump Angle – 120°

Specifications

Gross Lifting Capacity.....50k | 60k lbs.
 Container Capacity6-30 Cu. Yds.
 Arm Length120"
 Tare Weight.....10,200 | 10,500 lbs.
 Hydraulic Capacity.....35 G.P.M
 Operating Pressure2,500 | 3,400PSI
 Cylinder Size.....10"OD, 3.5" Shaft
 Rear Stabilizers..... Hydraulic Vertical
 Dump OperationHydraulic Pins

Cycle Time

Down Position.....59 Seconds
 Up Position.....48 Seconds
 Subframe.....10" Structural
 Side Box.....1/2" | 5/8" Plate
 Floor Plate.....5/16" | 3/8" Plate
 Lifting Chains.....1/2" | 5/8" Alloy
 Controls..... In Cab Air

Truck Requirements

Tandem Axle.....44,000 | 50,000 lbs.
 Front Axle.....18,000 | 20,000 lbs.
 Back of Cab to C/T..... 156"
 Center of Gravity.....36"
 Back of Cab-End of Frame.....206"
Please Add 8"-12" for Tarp System

Options

Tarp System, Tool Box, Auto Grease System, Wireless Controls, Tie Downs, 4-Hole Lift Keys, Work Lights, Scale Systems, Additional Axles and many more!

Ace is a Brother's Equipment, Inc Brand © January 2019 Brother's Equipment, Inc. All Rights Reserved. Specifications subject to improvement without notice. Equipment displayed should be operated by properly trained personnel. Operators should become familiar with OSHA, ANSI and any other applicable standards or laws for using this equipment. Improper use, misuse, or lack of maintenance could cause injury to people and/or property. Photos used in the literature are illustrative only. We assume no liability or responsibility for proper training/operation of equipment not manufactured by Brother's Equipment, Inc.