

ACDT-70-233TF 20ft Intermodal Container Dump Trailer

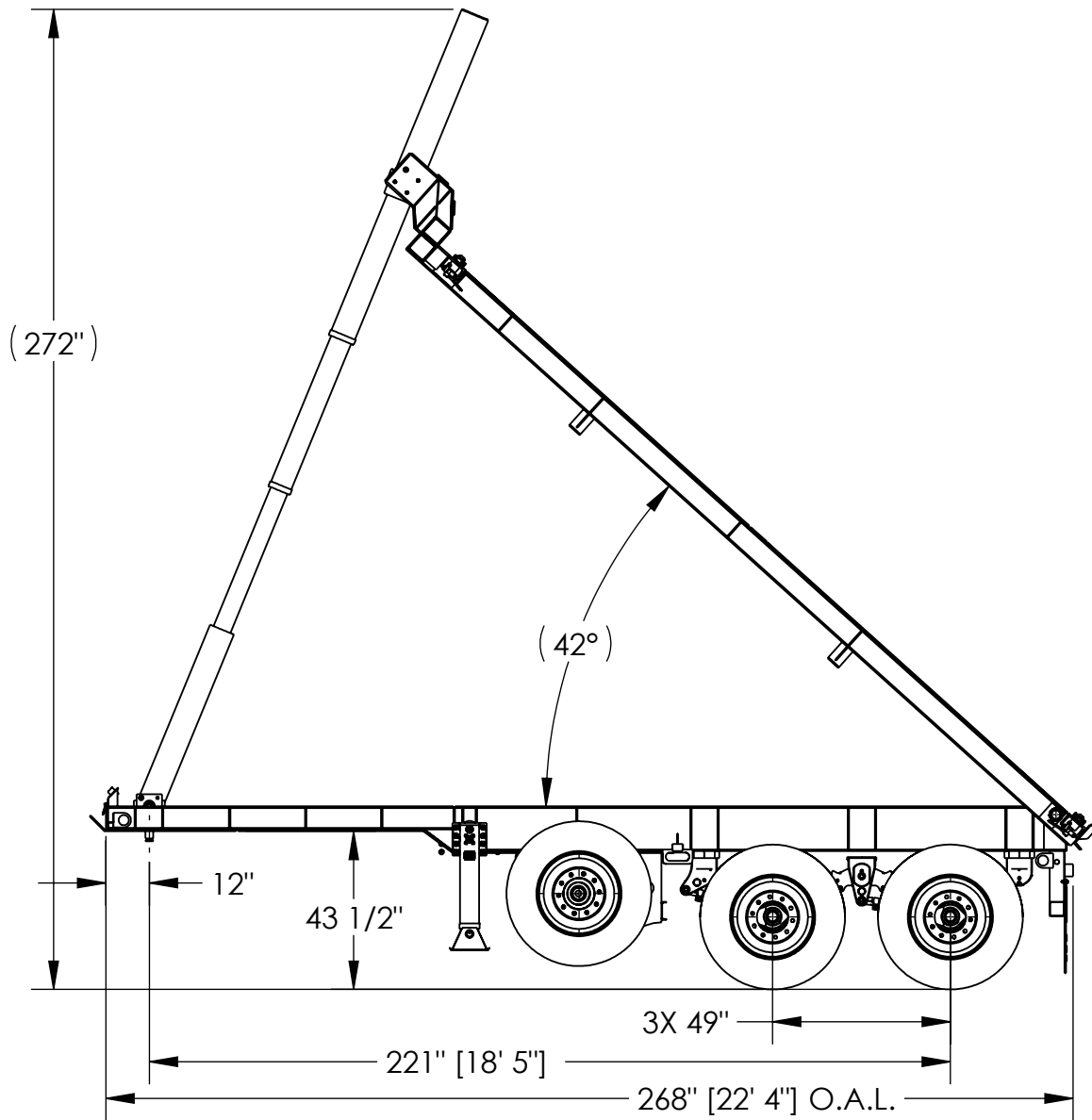

General Specifications

Payload: 70,000 lbs 20ft Intermodal Containers

Kingpin: 3/8" King Pin Plate, 12" King Pin Center

Main Beam: 12x30 W Beam, 6x25 Gooseneck

ASTM A992 Steel, Reinforced Frame wrap

Hoist Frame: 6x25 W Beam ASTM A992 Steel

Cross Member: 10" Channel ASTM A36

Locking Mechanism: Front and Rear Twistlocks

Landing Gear: 60,000 lbs capacity, 17" travel, low "T" shoes. Driver side crank handle.

Cylinder: Front Mount Single Lift Cylinder, 1" Hose

Suspension: Tandem Hutch 9700 Spring Suspension

Axles: 5" Meritor, 25,000 lb capacity, 7.5x16" drum brakes

Lift Axle: 5" Ridewell, 7" of lift with 22,500 lb capacity

Wheels: 22.5 x 8.25 hub-piloted Uni-Mount Steel Rims

Tires: 11R22.5 Radial Tires

Brake System: ABS (first & third axle std), Auto Slack adjusters, T30/30 Brake Chambers with 2.5" stroke. Meets FMSVSS 121

Electrical/Pneumatic: All lights, wiring and lines meet DOT-108 Regulations

Finish: Cleaned and coated with Epoxy Primer and acrylic urethane topcoat, Black

Safety Marking: Installed per federal regulations

The information contained in this drawing is for quoting purpose only, Brothers Equipment reserves the right to make changes at any time without notice.



Brothers Equipment Inc.

1335 East 171st Street, Cleveland, Oh. 44110
800-578-8471 www.theaceadvantage.com